

R-300 Flow Meter

FLOWREAD®

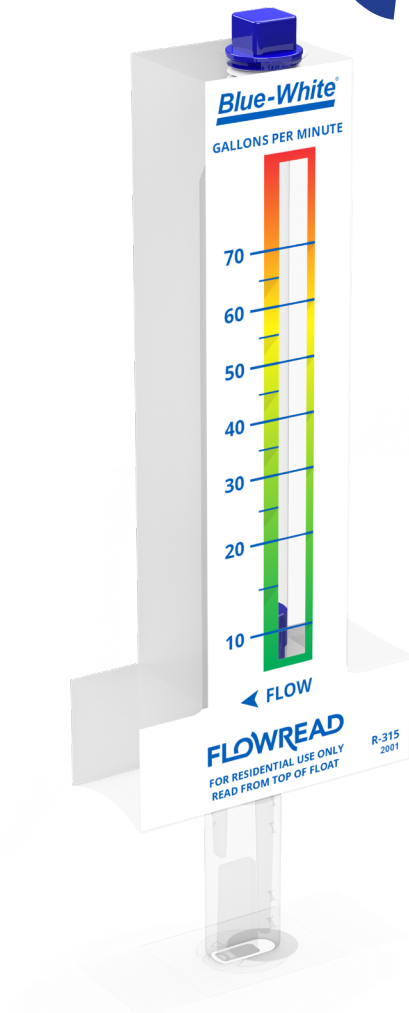

READ THE ENTIRE OPERATING MANUAL PRIOR TO INSTALLATION AND USE.



+1 (714) 893 - 8529



sales@blue-white.com



customerservice@blue-white.com





5300 Business Drive
Huntington Beach, CA 92649

Table of Contents

1.0 Introduction	5
1.1 What's in the box	5
1.2 Features	5
1.3 Ordering Information / Product Matrix	5
<hr/>	
2.0 Engineering Specifications	6
2.1 Materials of Construction	6
2.2 Flow Specifications	6
2.3 Dimensions	6
<hr/>	
3.0 Installation	7
3.1 Installation Requirements	7
3.2 Tools Required	7
3.3 Installation Instructions	8
3.4 Optional F-300S Flow Switch	8
3.5 Typical Installation with Flow Switch	9
<hr/>	
4.0 Reading your Flow Meter	9
<hr/>	
5.0 Maintenance and Troubleshooting	10
<hr/>	
6.0 Spare Parts	10
<hr/>	
7.0 Warranty	11

SAFETY INFORMATION

Please read this manual completely before unpacking, installing, and operating this equipment. In particular, pay attention to all dangers, warnings, and precautions, otherwise, it may cause serious injury to the operator or damage to the equipment.

Symbol	Description
	Warning (Risk of electric shock)
	Caution (Refer to the user's guide)
	Ground, Protective Conductor Terminal

Note: When in doubt regarding your electrical installation, contact a licensed electrician.

1.0 Introduction

Congratulations on purchasing the FlowRead® R-300 Flow Meter!

Your Flow Meter is calibrated and ready for use. The unit is designed to give many years of service. For more information or questions on this product or any of our Aquatics/Industrial products, please visit us at www.blue-white.com



Scan the QR code to access our mobile-friendly Support Hub, where you can view manuals, watch installation and maintenance videos, contact Blue-White, live chat with customer service, and use our pool flow rate calculator to set your pool pump correctly.

1.1 What's in the box

- Flow meter (1), Rubber Gasket (1), Clamps (2)
- Quick Start Guide

Check all packaging for completeness and inspect for damage before installation.

1.2 Features

- Easy to Read scale in Gallons per Minute, screen printed on both sides
- Tested and calibrated for clean water applications
- Acceptable for outdoor installations - One piece machined acrylic meter body
- Pitot tube design makes it easy to install on piping
- Eliminate guesswork when running a variable speed pump

1.3 Ordering Information / Model Number Matrix

R-300 Model Number

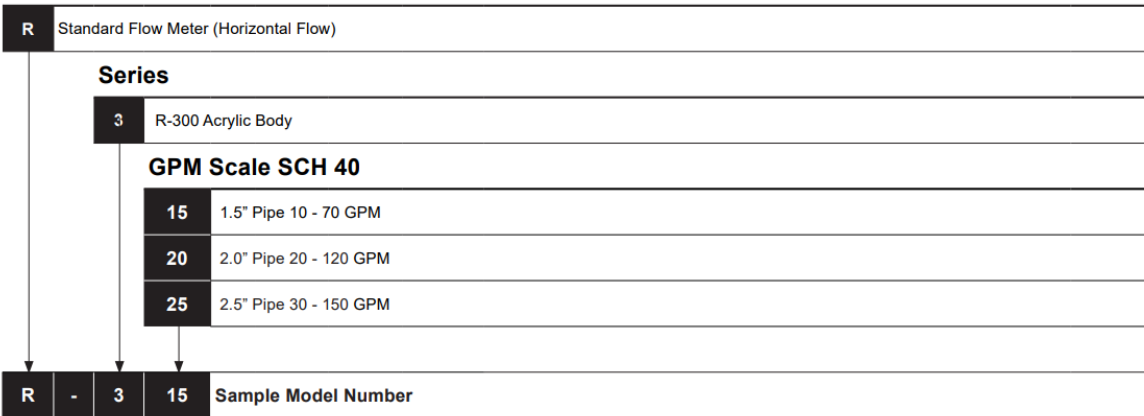

R-300

2.0 Engineering Specifications

Pipe Requirements	IPS inch pipe size (ASTM-D-1785)
Maximum Working Pressure	75 PSI (5.2 bar) at 70 °F (21 °C)
Fluid Temperature Range	0° to 190 °F / -18 to 88 °C @ 0 PSI
Ambient Temp Range	0° to 110 °F / -18 to 43 °C
Full Scale Accuracy	5% of rate
Calibration Fluid	Water, specific gravity 1.0
Approximate Shipping Weight	1.5" - 2.5" units: 1 lb (.45kg)

2.1 Materials of Construction

Wetted Components:

Meter Body	Acrylic
Float	PVDF
Gasket	Neoprene
Pipe Clamp	316SS

2.2 Flow Specifications

Models for Mounting on Horizontal Pipe
 Models for U.S. IPS Sch 40 Pipe
 (ASTM 1785)

Model	Pipe size	Sch40	Sch80
R-315	1-1/2"	10 to 70	10 to 60
R-320	2"	20 to 120	18 to 100
R-325	2-1/2"	30 to 120	25 to 130

2.3 Dimensions

R-300 Series

Model	Pipe Size	A	B
R-315	1-1/2"	6"	2-7/16"
R-320	2"	6"	2-7/16"
R-325	2-1/2"	6"	2-7/16"

Maximum Temperature vs. Pressure

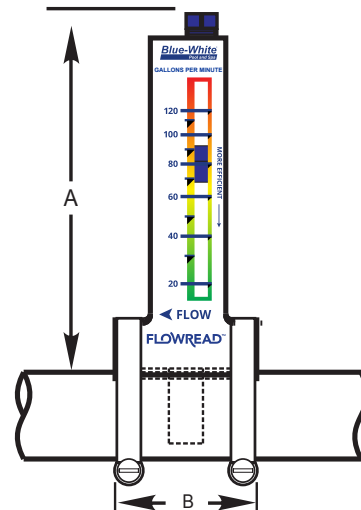
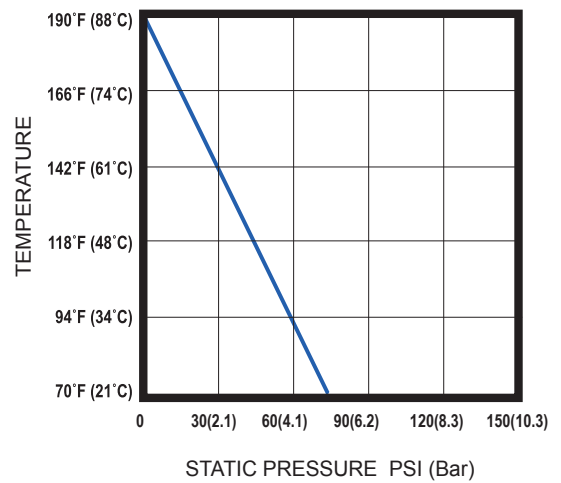

3.0 Installation and Wiring (if using flow switch)



Always wear protective clothing, face shield, safety glasses and gloves when working on your equipment. Use caution when lifting and mounting equipment. When in doubt, contact factory for assistance.

3.1 Installation Requirements

Before beginning installation, review your system flow and pressure to ensure your F-300 is proper for your system parameters.

Pipe Requirements: To prevent debris from entering the meter, install the flow meter downstream from the filter if possible. Pipe should be clean and free of debris on outside. Pipe should be uniform, not warped, and free of stress. Pipe must be properly support and vibration free. Choose location where pipe will be full at all times.

Straight Pipe Requirements: Ensure there is the minimum straight length of pipe before and after the flow meter.

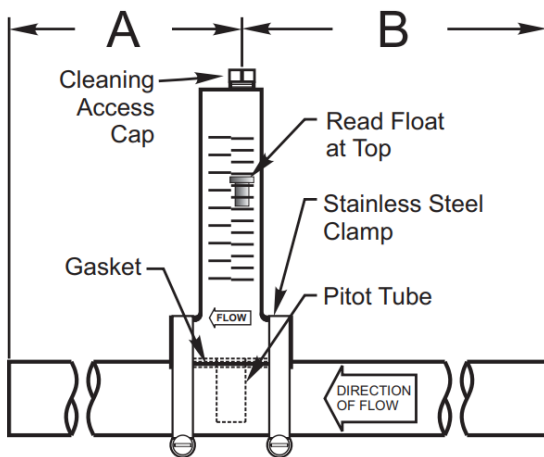

Dimension	Pipe Requirement
A	Outlet pipe length = 2 x Pipe I.D.*
B	Inlet pipe length = 5 x Pipe I.D.*

* Minimum acceptable dimensions.

3.2 Tools Required

- Drill
- Drill bit 5/8"
- Drill bit 1/4" (Optional pilot hole)
- Fine sandpaper or Deburring Tool (Optional)
- Felt pen (dry erase)
- Tape measure
- Flathead screwdriver (or nut driver) for clamp tightening

Note: Keep flow meter away from pipe glue fumes. Ensure all pipe glue is dry before installation flow meter. Pipe glue solvents will damage acrylic.



[Link to Instructional Installation Video](#)

3.3 Installation Instructions

1. Turn off pump and ensure there is no pressure in pipe before installation.
 2. Ensure Straight Length of Pipe requirements are met when choosing an installation location.
 3. Choose a location where the meter is easy to read.
 4. Mark the location of the hole on the pipe. Ensure the hole is on the top of the pipe in the 12 O’Clock position.
 5. Drill the hole using the proper size drill bit. Use a pilot hole drill bit for easier installation.
 6. Carefully Remove all burrs and sand hole to ensure an smooth insertion.
 7. (If using a F-300S switch, install the new magnetized float in the R-300 now.)
 8. Ensure gasket is on pitot tube portion of flow meter, and insert pitot tube into hole. Ensure gasket seats properly and the flow arrow is pointed in the direction of flow.
 9. Place clamps and tighten. Alternately tighten each clamp for uniform installation. (An additional person to assist here may be desired.)
 10. Check alignment and direction of flow again. (R-300 can only measure flow in one direction.)
 11. Add water pressure/flow and check for leaks and proper float movement.
- Note: See information in Maintenance section regarding storge during winter.

Examples:

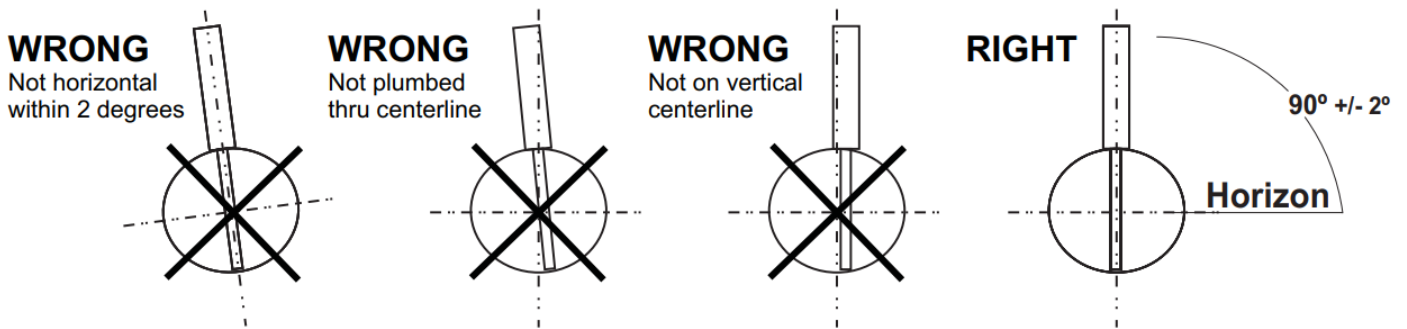

3.4 Optional F-300S Flow Switch

Instruction for the F-300S Flow Switch (purchase separately) for use with your Flow Meter. Flow Switch / Sensor is designed to detect Flow / No Flow. When the PVDF float passes through the Alarm Trigger Zone (Hysteresis) of the Sensor Accessory, the built-in contact closure switch sends a signal to external devices.

1. F-300S comes with a new magnetized float. To install the new float, remove the top cap, remove the red float, place the new magnetized float into the body with the wider diameter at the top, and thread the red cap back onto the flow meter.
2. Easily install the F-300S switch by lowering it over the top of the flow meter.
3. Tighten the Lock-Screw at the desired flow level.
4. Wiring is simple normally open, form A, SPST, contact closure wiring (see diagram on next page) (Normally closed option available. Use F-300SNC)
5. Keep wiring clear of pump power wiring and VFD wiring.

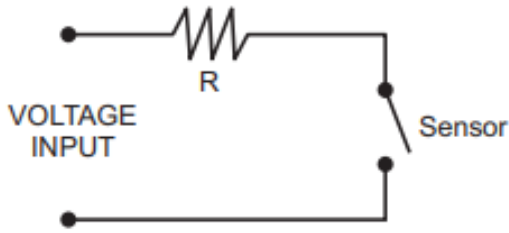

High surge currents may cause damage to the sensor and significantly reduce its life, the following circuit is, therefore, highly recommended.

VOLTAGE @ Max AMP. (V)	Minimum R (OHM) ± 20%
30 DC/AC @ .033 AMP.	1000
24 DC/AC @ .040 AMP.	680
12 DC/AC @ .083 AMP.	150
6 DC/AC @ .166 AMP.	36
4 DC/AC @ .250 AMP.	16

3.5 Typical Installation with Flow Switch

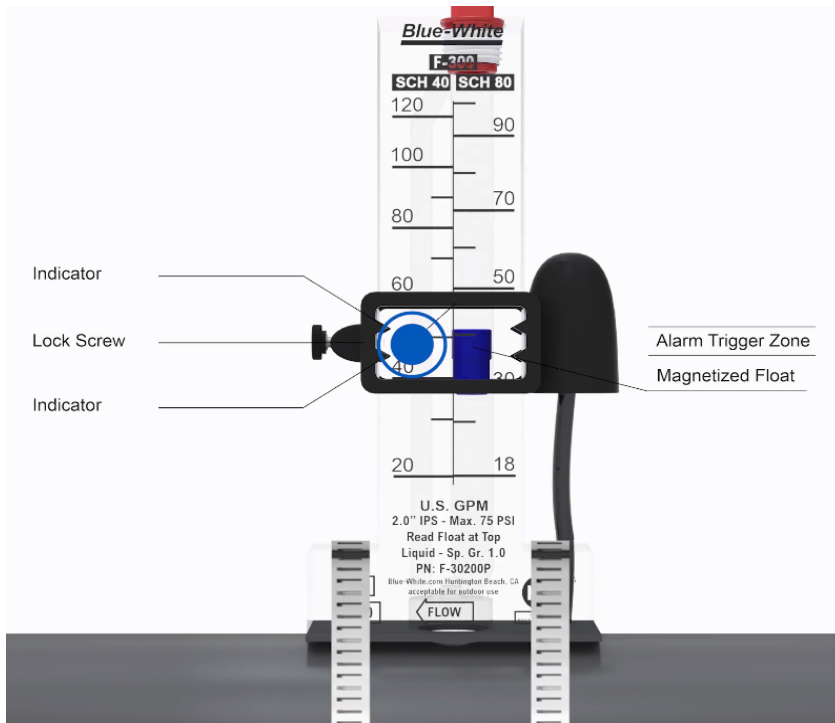

4.0 Reading your R-300 Flow Meter

Avoid imposing a sudden burst of flow to the meter. Solenoid valves may cause the float to impact the top float stop with destructive force. Always read float at top.

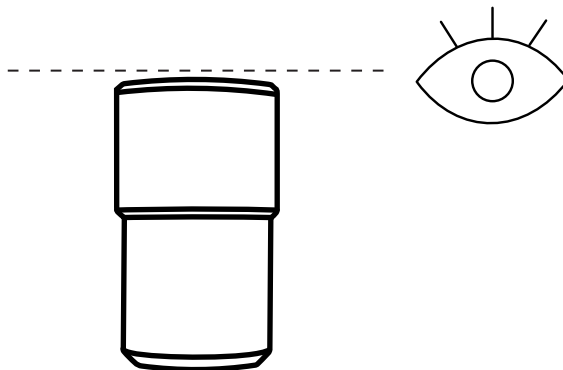

Float

5.0 Maintenance and Troubleshooting

- The R-300 Flow Meter requires very little maintenance. However, the flow meter may become clogged due to excess debris in the water. If this happens, simply shut off the process pump and remove any pressure from the piping. If isolation valves are installed, shut these to minimize the amount of water that may leak. Remove the top cap at the top, remove and clean any debris in the flow meter. Use soft bristle brush.
- It may be necessary for the complete flow meter to be removed for thorough cleaning. If so, loosen the stainless-steel clamps so the meter can be fully removed from the pipe. Inspect the meter and clean it with mild soap. Off-season cleaning is recommended when the R-300 is not used for a period of time.
- Reinstall the flow meter and test. If the float was removed during the cleaning process, ensure the float was reinstalled properly. The float is wider at the top.
- **Winterize.** If installed outside, or if not being used for a period of time, we recommend removing the meter from the pipe, cleaning thoroughly, and storing it indoors for the winter. While the meter can withstand cold temperatures and outdoor conditions, expansion and contraction caused by freezing water can cause stress to the meter components that might result in cracking. Clean the meter inside and out prior to re-installing.

6.0 Spare Parts

R-300 Replacement Parts

Item	Model No.	Product Name	Qty. Req.
1	91001-327	Blue Cap Plug R-300	1
2	71010-697	Short Float, blue PVDF	1
3	F-3003	Gasket Seal	1
4	90008-652	Mounting Clamp R-315, R-320	2
	90008-668	Mounting Clamp R-325	2

F-300S Flow Switch

MODEL NO.	PIPE SIZES
F-300S	1.5", 2", 2.5"
(F300SNC - Normally closed option)	

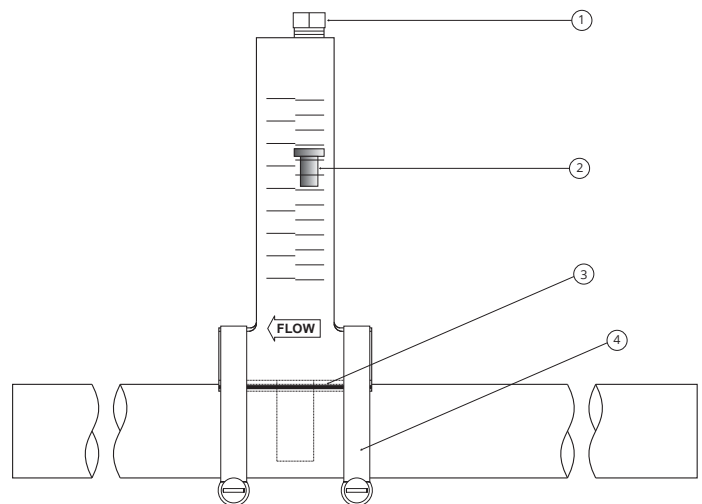

F-300S FLOW SWITCH

7.1 LIMITED WARRANTY

Your new Flow Meter is a quality product and is warranted for 12 months from date of purchase (proof of purchase is required). The unit will be repaired or replaced at our discretion. Failure must have occurred due to defect in material or workmanship and not as a result of operation of the product other than in normal operation as defined in the manual. Warranty status is determined by the serial label and the sales invoice or receipt. The serial label must be on the unit and legible. The warranty status of the unit will be verified by Blue-White or a factory authorized service center.

7.2 WHAT IS NOT COVERED

- Wear items.
- Unit removal, or re-installation, and any related labor charge.
- Freight to the factory, or service center.
- Units that have been tampered with, or in pieces.
- Damage to the unit that results from misuse, carelessness such as chemical spills on the enclosure, abuse, lack of maintenance, or alteration which is out of our control.
- Units damaged by faulty wiring, power surges or acts of nature.

7.3 PROCEDURE FOR IN WARRANTY REPAIR

Contact the factory to obtain a RMA (Return Material Authorization) number. Carefully pack the unit to be repaired. Please enclose a brief description of the problem as well as the original invoice or sales receipt, or copy showing the date of purchase. Prepay all shipping costs. COD shipments will not be accepted. Warranty service must be performed by the factory or an authorized service center. Damage caused by improper packaging is the responsibility of the sender. When In-Warranty repair or replacement is completed, the factory pays for return shipping to the dealer or customer.

7.4 PRODUCT USE WARNING

Blue-White products are manufactured to meet the highest quality standards in the industry. Each product instruction manual includes a description of the associated product warranty and provides the user with important safety information. Purchasers, installers, and operators of Blue-White products should take the time to inform themselves about the safe operation of these products. In addition, Customers are expected to do their own due diligence regarding which products and materials are best suited for their intended applications. Blue-White is pleased to assist in this effort but does not guarantee the suitability of any particular product for any specific application as Blue-White does not have the same degree of familiarity with the application that the customer/end user has. While Blue-White will honor all of its product warranties according to their terms and conditions, Blue-White shall only be obligated to repair or replace its defective parts or products in accordance with the associated product warranties. **BLUE-WHITE SHALL NOT BE LIABLE EITHER IN TORT OR IN CONTRACT FOR ANY LOSS OR DAMAGE WHETHER DIRECT, INDIRECT, INCIDENTAL, OR CONSEQUENTIAL, ARISING OUT OF OR RELATED TO THE FAILURE OF ANY OF ITS PARTS OR PRODUCTS OR OF THEIR NONSUITABILITY FOR A GIVEN PURPOSE OR APPLICATION.**

7.5 CHEMICAL RESISTANCE WARNING

Blue-White offers a wide variety of wetted parts. Purchasers, installers, and operators of Blue-White products must be well informed and aware of the precautions to be taken when injecting or measuring various chemicals, especially those considered to be irritants, contaminants or hazardous. Customers are expected to do their own due diligence regarding which products and materials are best suited for their applications, particularly as it may relate to the potential effects of certain chemicals on Blue-White products and the potential for adverse chemical interactions. Blue-White tests its products with water only. The chemical resistance information included in this instruction manual was supplied to Blue-White by reputable sources, but Blue-White is not able to vouch for the accuracy or completeness thereof. While Blue-White will honor all of its product warranties according to their terms and conditions, Blue-White shall only be obligated to repair or replace its defective parts or products in accordance with the associated product warranties. **BLUE-WHITE SHALL NOT BE LIABLE EITHER IN TORT OR IN CONTRACT FOR ANY LOSS OR DAMAGE, WHETHER DIRECT, INDIRECT, INCIDENTAL, OR CONSEQUENTIAL, ARISING OUT OF OR RELATED TO THE USE OF CHEMICALS IN CONNECTION WITH ANY BLUE-WHITE PRODUCTS.**

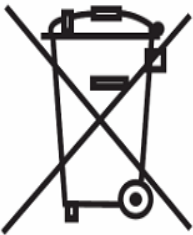

Users of electrical and electronic equipment (EEE) with the WEEE marking per Annex IV of the WEEE Directive must not dispose of end of life EEE as unsorted municipal waste, but use the collection framework available to them for the return, recycle, recovery of WEEE and minimize any potential effects of EEE on the environment and human health due to the presence of hazardous substances. The WEEE marking applies only to countries within the European Union (EU) and Norway. Appliances are labeled in accordance with European Directive 2002/96/EC.

Contact your local waste recovery agency for a *Designated Collection Facility* in your area.

Blue-White[®]